

PRELIMINARY SPEC

Part Number: AAD1-9090SE9ZC/2

Reddish-Orange

### Features

- SUPER HIGH FLUX OUTPUT AND HIGH LUMINANCE.
- DESIGNED FOR HIGH CURRENT OPERATION.
- LOW THERMAL RESISTANCE.
- LOW VOLTAGE DC OPERATED.
- SUPERIOR ESD PROTECTION.
- PACKAGE: 500PCS/REEL.
- NOT REFLOW COMPATIBLE.
- THE COMPONENT IS INTERNALLY PROTECTED WITH SILICONE GEL.
- RoHS COMPLIANT.



### Applications

- traffic signaling.
- backlighting (illuminated advertising , general lighting).
- interior and exterior automotive lighting.
- substitution of micro incandescent lamps.
- portable light source (e.g. bicycle flashlight).
- signal and symbol luminaire for orientation.
- marker lights (e.g. steps, exit ways, etc).
- decorative and entertainment lighting.
- indoor and outdoor commercial and residential architectural lighting.

### Package Dimensions

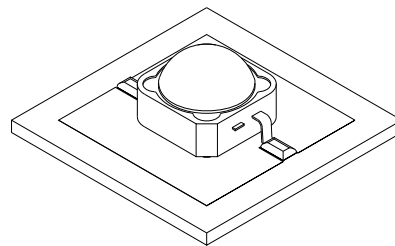
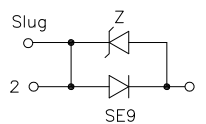
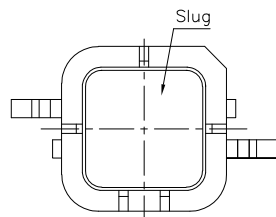
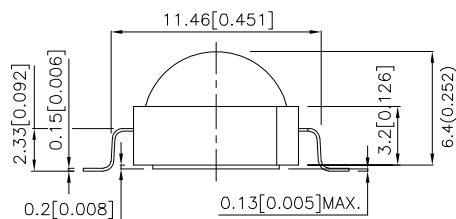
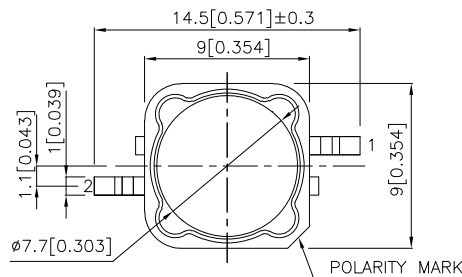

#### Notes:

1. All dimensions are in millimeters (inches).
2. Tolerance is  $\pm 0.25(0.01)$  unless otherwise noted.
3. Specifications are subject to change without notice.
4. The device has a single mounting surface. The device must be mounted according to the specifications.



## Selection Guide

Part No.	Dice	Lens Type	luminous Intensity lv (cd)@ 500 mA [2]		$\Phi_v$ (lm) @ 500 mA [2]		Viewing Angle [1]
			Min.	Typ.	Min.	Typ.	2 $\theta$ 1/2
AAD1-9090SE9ZC/2	REDDISH-ORANGE (AlGaInP)	WATER CLEAR	12	17	35	42	100°

Notes:

1.  $\theta$ 1/2 is the angle from optical centerline where the luminous intensity is 1/2 the optical centerline value.
2. Luminous intensity/ luminous Flux: +/-15%.

## Absolute Maximum Ratings at TA=25°C

Parameter	Symbol	Value	Unit
Power dissipation	Pt	1.62	W
Junction temperature	TJ	110	°C
Operating Temperature	Top	-40 To +100	°C
Storage Temperature	Tstg	-40 To +100	°C
DC Forward Current [1]	IF	500	mA
Peak Forward Current [2]	IFM	700	mA
Thermal resistance [1]	Rth j-slug	12	°C/W
Electrostatic Discharge Threshold (HBM)		8000	V
Iron Soldering [3]		350°C For 3 Seconds	

Notes:

1. Metal Core PCB is mounted on the heat Fins.
2. 1/10 Duty Cycle, 0.1ms Pulse Width.
3. 1.29mm below package base.

## Electrical / Optical Characteristics at TA=25°C

Parameter	Symbol	Value	Unit
Wavelength at peak emission IF=500mA [Typ.]	$\lambda_{peak}$	628	nm
Dominant Wavelength IF=500mA [Typ.]	$\lambda_{dom}$ [1]	623	nm
Spectral bandwidth at 50% $\Phi_{REL MAX}$ IF=500mA [Typ.]	$\Delta\lambda$	22	nm
Forward Voltage IF=500mA [Min.]	VF [2]	2.4	V
Forward Voltage IF=500mA [Typ.]		3.0	
Forward Voltage IF=500mA [Max.]		3.6	
Temperature coefficient of $\lambda_{peak}$ IF=500mA, -10°C ≤ T ≤ 100°C [Typ.]	TC $\lambda_{peak}$	0.08	nm/°C
Temperature coefficient of $\lambda_{dom}$ IF=500mA, -10°C ≤ T ≤ 100°C [Typ.]	TC $\lambda_{dom}$	0.03	nm/°C
Temperature coefficient of VF IF=500mA, -10°C ≤ T ≤ 100°C [Typ.]	TCv	-2.8	mV/°C

Notes:

1. Wavelength: +/-1nm.
2. Forward Voltage: +/-0.1V.

## AAD1-9090SE9ZC/2

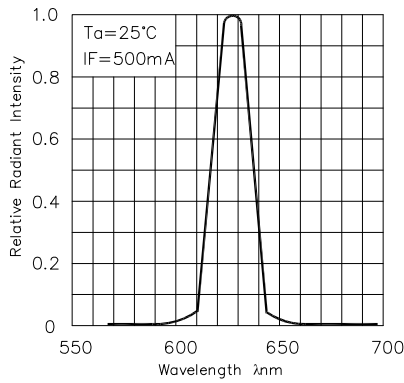

RELATIVE INTENSITY vs. WAVELENGTH

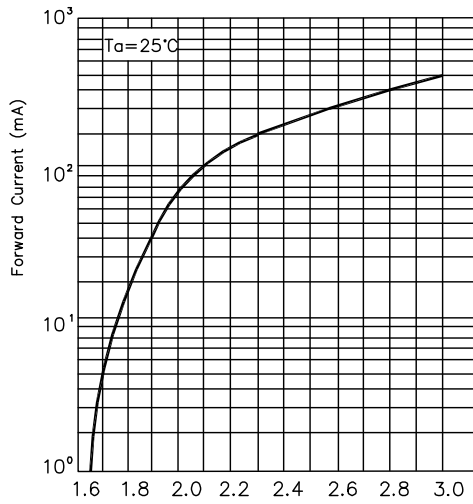
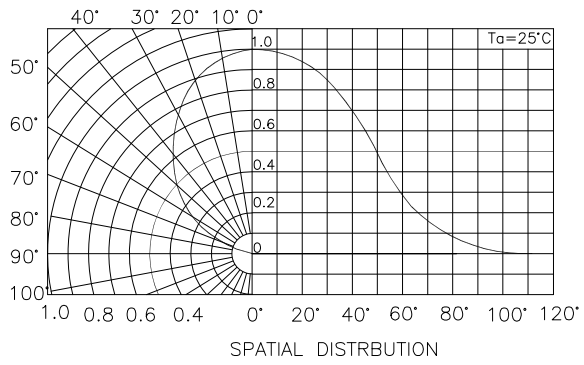

FORWARD CURRENT vs. FORWARD VOLTAGE

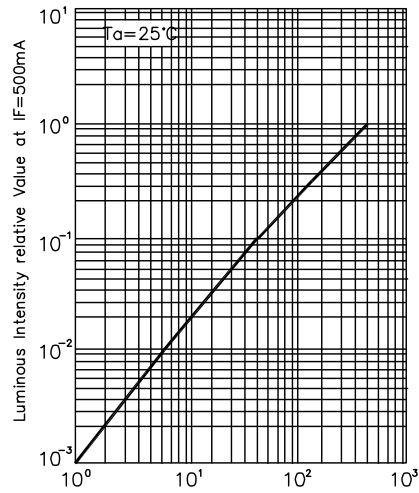

LUMINOUS INTENSITY vs. FORWARD CURRENT

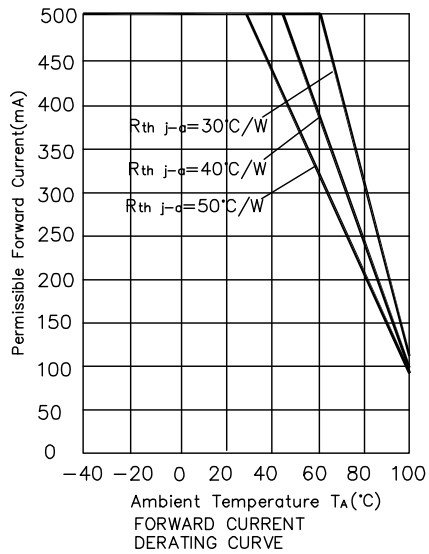

FORWARD CURRENT DERATING CURVE

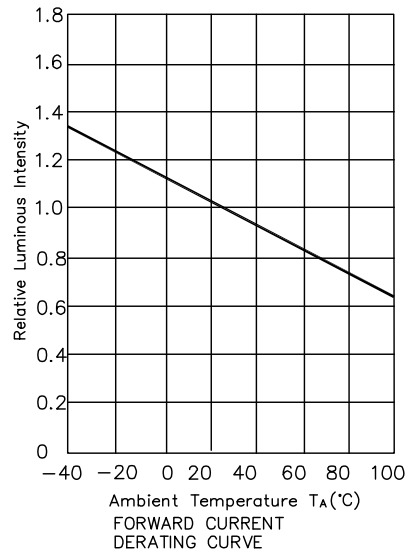

FORWARD CURRENT DERATING CURVE

## AAD1-9090SE9ZC/2

### Recommended Soldering Pattern

(Units : mm; Tolerance:  $\pm 0.1$ )

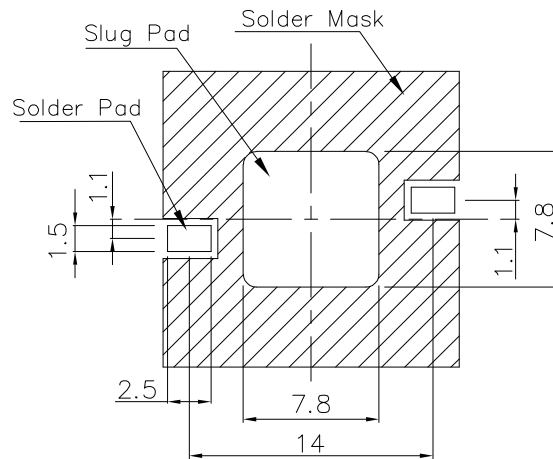

### Tape Specifications (Units : mm)

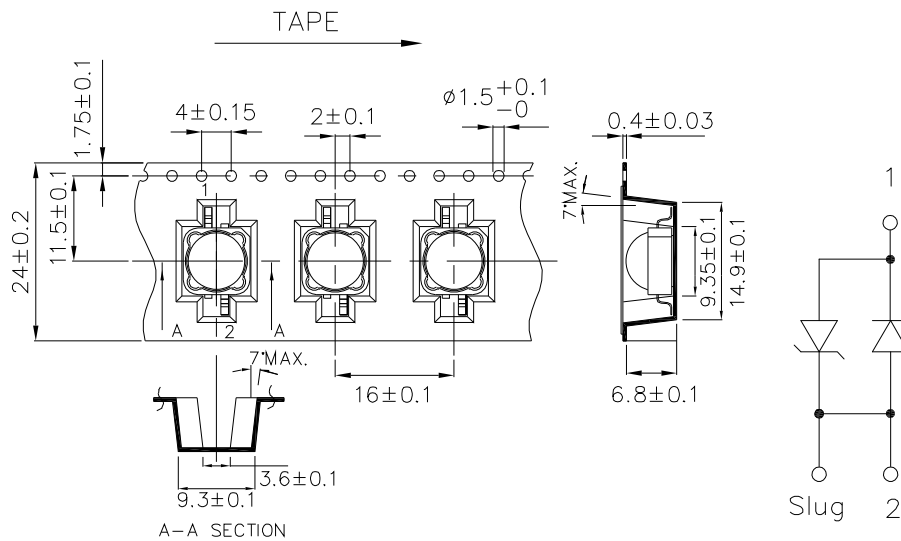

## AAD1-9090SE9ZC/2

### Recommended Solder Steps

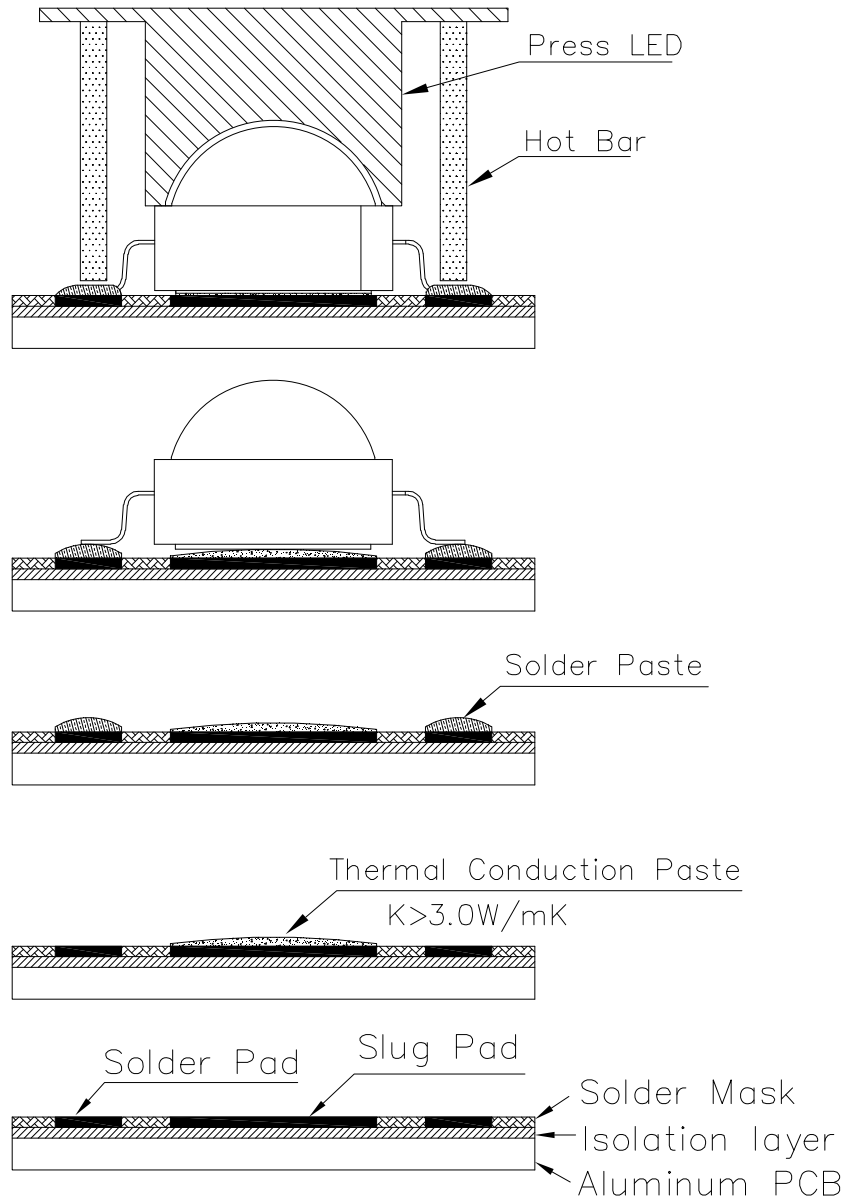

## PACKING & LABEL SPECIFICATIONS

AAD1-9090SE9ZC/2

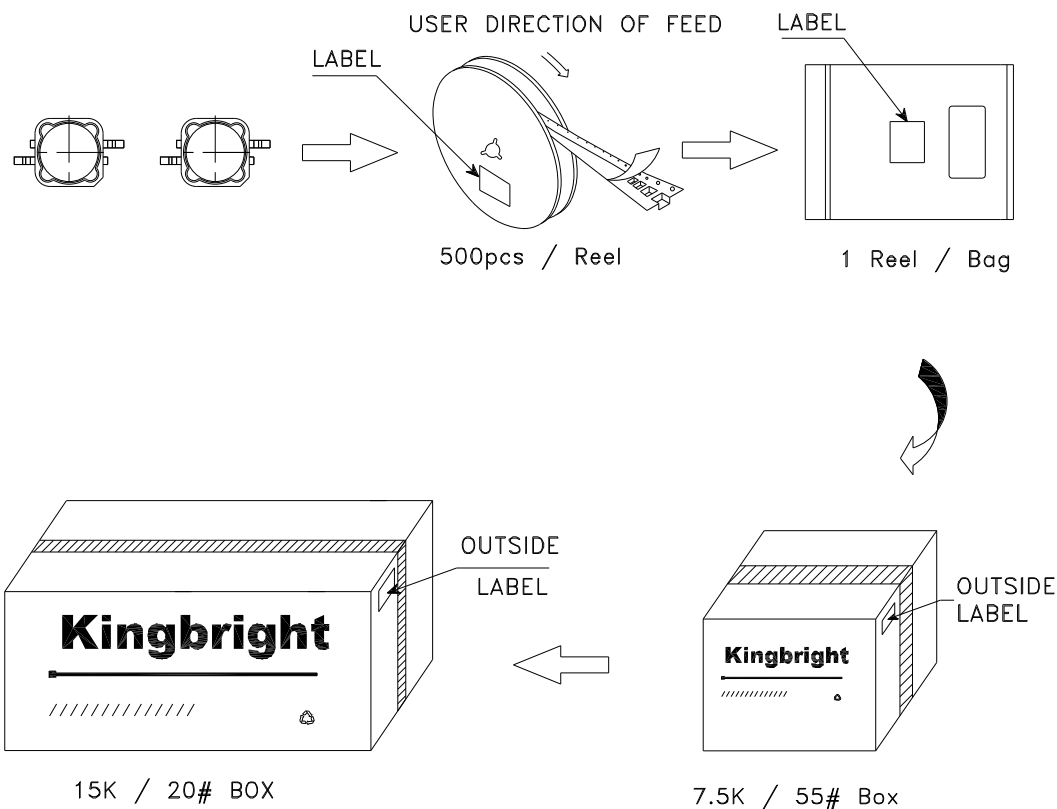

<h1>Kingbright</h1>	
P/NO: AAD1-9090xxx	
QTY: 500 pcs	Q.C. <span style="border: 1px solid black; border-radius: 50%; padding: 2px;">QC XX XX XXXX PASSED</span>
S/N: XXXX	
CODE: XXX	
LOT NO:	
 xxxxxxxxxxxxxxxxxxxxxxxx	
RoHS Compliant	